

# Installation instructions

<b>VMG LIGNUM BOARD</b>	<b>2</b>
<b>VMG LIGNUM BOARD   FLOOR REGULAR</b>	<b>4</b>
<b>VMG LIGNUM BOARD   FLOOR T&amp;G2</b>	<b>6</b>
<b>VMG LIGNUM BOARD   FLOOR T&amp;G4</b>	<b>8</b>
<b>VMG LIGNUM BOARD   WALL REGULAR</b>	<b>10</b>
<b>VMG LIGNUM BOARD   WALL T&amp;G2</b>	<b>12</b>

# VMG Lignum Board

## GENERAL

These guidelines are for the installation of **VMG Lignum Board | Floor Regular**.

There are three types of **VMG Lignum Board | Floor**:

- has tongue and groove on four sides **VMG Lignum Board | Floor T&G4**.
- has tongue and groove on two sides **VMG Lignum Board | Floor T&G2**.
- has straight edges **VMG Lignum Board | Floor Regular**.

Marking on plate should be always on bottom side of plate.

**VMG Lignum Board | Floor** contains 5-8 % moisture on delivery from factory. During assembling of plates, materials cannot get direct water (rain) and temperature should be +10°C at least.

The panels will move slightly in response to variations in air humidity.

## AREAS OF USE

VMG Lignum Board can be use as a floor (Service class 1&2), subfloors for repairing, renovations, walls, roofs, formworks and other constructions purposes. Using for all constructions, loads should be evaluated according to local valid norms, distances of constructions and fixing should be designed.

## TRANSPORT, STORAGE, HANDLING

**VMG Lignum Board** must be protected from moisture during transport and storage. Panels must never be laid directly on the ground.

**VMG Lignum Board** should be stacked horizontally on wooden battens (100 x 80 mm). Wooden battens should be of the same dimensions and spaced no further than 950 mm apart. At the edges, **VMG Lignum Board** should not project from the last wooden battens by more 305 mm. Wooden battens should be vertically aligned to avoid damage (Fig. 1).

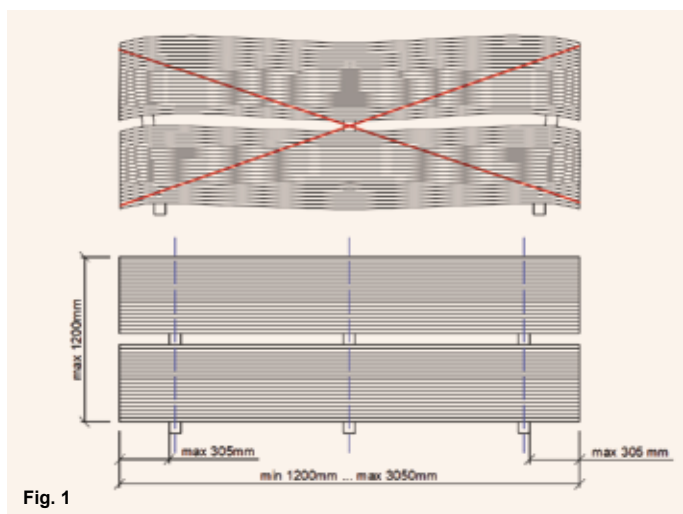

Fig. 1

The corners of plates are protected at the factory.

## PLEASE HANDLE WITH CARE!

**VMG Lignum Board** should be carried by hand in a vertical position, not horizontal, in order to avoid breaking (Fig. 2).

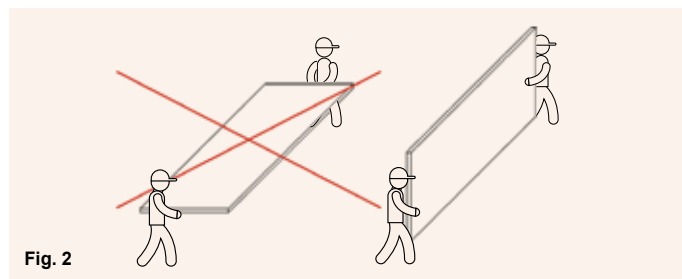

Fig. 2

Storage rooms must be protected from the direct sun and rain (Fig. 3). Open shelters are not considered dry.

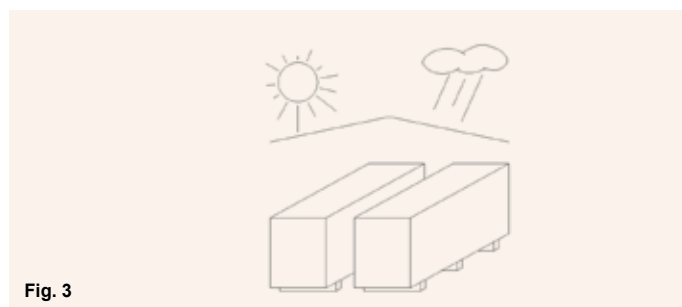

Fig. 3

# VMG Lignum Board T&G4

## BEARING STRUCTURES

VMG Lignum Board can be placed on:

- wooden beams.
- metal beams.

## INSTALLATION ON BEAMS

The moisture content of the wood beams cannot exceed 18 %. The bearing structure should be leveled. A vapour barrier can be placed between the bearing structure and **VMG Lignum Board**. The beams must be installed with exact centre-to-centre spacing, max. c/c 600 mm (Fig. 4).

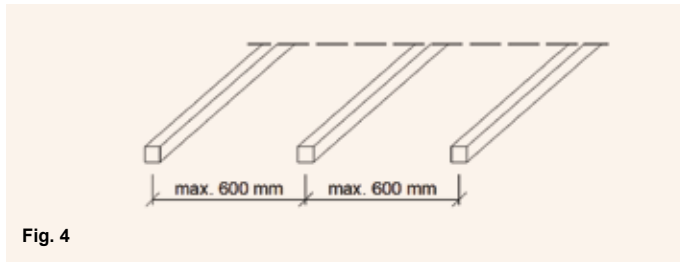

Fig. 4

VMG Lignum Board should always be perpendicular to the direction of the beams (Fig. 5). All short panel edges must be supported. VMG Lignum Board must span at least two beam gaps. It is recommended to connect on the center line of the beam (Fig. 5), but boards can also be installed with the end joint between the beams without support. (Fig. 5a). In this case minimum distance from beam to joint should be 160 mm.

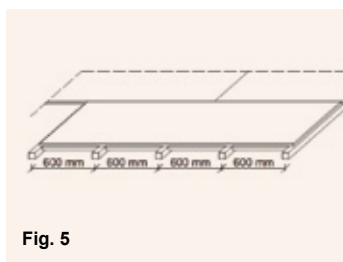

Fig. 5

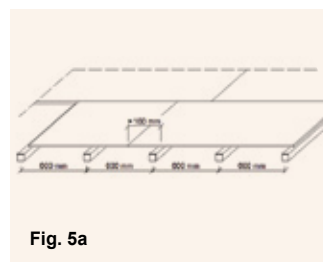

Fig. 5a

VMG Lignum Board are nailed or screwed. In service class 1, galvanize steel or stainless steel and in service class 2 - hot galvanized steel or stainless steel fasteners must be used. The minimum length of fasteners must be at least 50 mm or twice the thickness of the panel, whichever is the longest. For nails, the minimum diameter is 0.16 times the thickness of the panel; and 0.2 times the thickness of the the panel for screws. Minimal nails 3.0/50 mm, screws 3.6/50 mm.

While mounting for other constructions (walls, roofs, formworks and etc) distance between fasteners should be evaluated by static calculations, if it is necessary.

The distance to the edge must be at least 12 mm, and to the corner - at least 25 mm (Fig. 6)

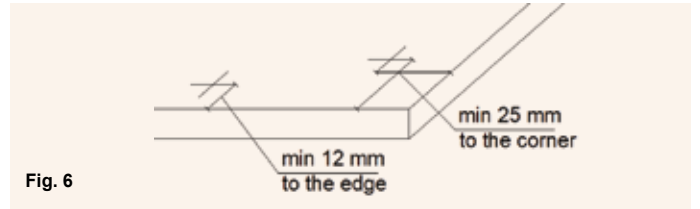

Fig. 6

The spacing between fasteners is not more than 150 mm at the ends of the panel and not more than 300 mm on intermediate supports (Fig. 7).

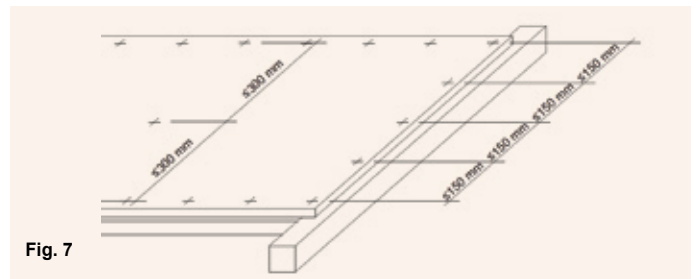

Fig. 7

To prevent the floor from cracking, the **VMG Lignum Board T&G** profiles must be fully glued (Fig. 8). The panels must be driven so tightly that adhesive emerges from the beam. Remove excess adhesive. Gluing the panels on the support beam contributes significantly to improving the overall resistance to vibrations of whole flooring. Recommendations for glues:

- in dry conditions, minimum PVAc, type D3.
- in wet conditions PVAc, type D4.

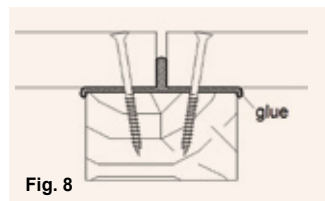

Fig. 8

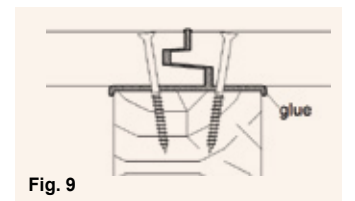

Fig. 9

While mounting for other constructions (walls, roofs, formworks and etc) glueing is not obligatory. Against fixed structures, there must be a clearance of min. 10 mm (Fig. 10). Large floor surfaces over 10 m long must be broken up into fields with expansion gaps between them.

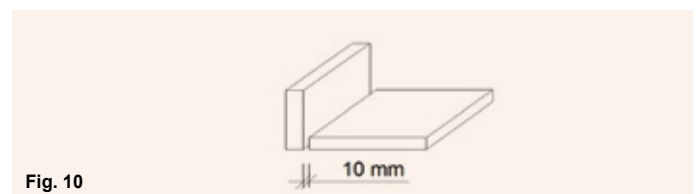

Fig. 10

Before laying the top floor, it must be checked that the subfloor has good contact with the joists and does not creak. If it does, consider inserting more screws. **VMG Lignum Board** damp content may not exceed 10% when the top floor is laid.

# VMG Lignum Board | Floor Regular

## GENERAL

These guidelines are for the installation of **VMG Lignum Board | Floor Regular**.

There are three types of **VMG Lignum Board | Floor**:

- has tongue and groove on four sides **VMG Lignum Board | Floor T&G4**.
- has tongue and groove on two sides **VMG Lignum Board | Floor T&G2**.
- has straight edges **VMG Lignum Board | Floor Regular**.

Marking on plate should be always on bottom side of plate.

**VMG Lignum Board | Floor** contains 5-8 % moisture on delivery from factory. During assembling of plates, materials cannot get direct water (rain) and temperature should be +10°C at least.

The panels will move slightly in response to variations in air humidity.

## AREAS OF USE

**VMG Lignum Board | Floor** can be use as a floor (Service class 1&2).

## TRANSPORT, STORAGE, HANDLING

**VMG Lignum Board/ Floor Regular** must be protected from moisture during transport and storage. Panels must never be laid directly on the ground.

**VMG Lignum Board | Floor Regular** should be stacked horizontally on wooden battens (100 x 80 mm). Wooden battens should be of the same dimensions and spaced no further than 950 mm apart. At the edges, **VMG Lignum Board | Floor Regular** should not project from the last wooden battens by more 305 mm. Wooden battens should be vertically aligned to avoid damage (Fig. 1).

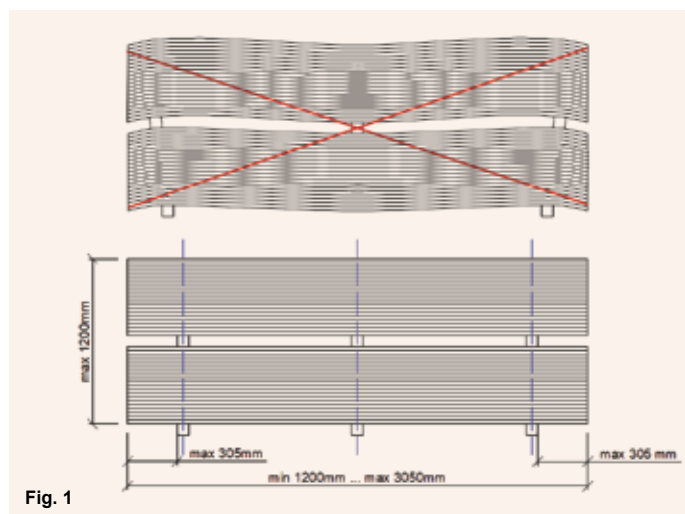

Fig. 1

The corners of the plates are protected at the factory.

## PLEASE HANDLE WITH CARE!

**VMG Lignum Board | Floor Regular** should be carried by hand in a vertical position, not horizontal, in order to avoid breaking (Fig. 2).

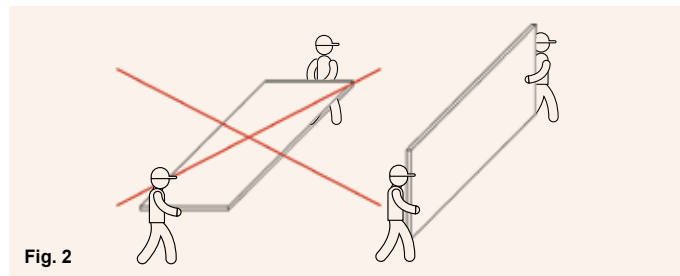

Fig. 2

Storage rooms must be protected from the direct sun and rain (Fig. 3). Open shelters are not considered dry.



Fig. 3

## BEARING STRUCTURES

**VMG Lignum Board | Floor Regular** can be placed on:

- wooden beams.
- metal beams.

# VMG Lignum Board | Floor Regular

## INSTALLATION ON BEAMS

The moisture content of the wood beams cannot exceed 18 %. The bearing structure should be leveled. A vapour barrier can be placed between the bearing structure and **VMG Lignum Board | Floor Regular**. The beams must be installed with exact centre-to-centre spacing, max c/c 600 mm (Fig. 4).

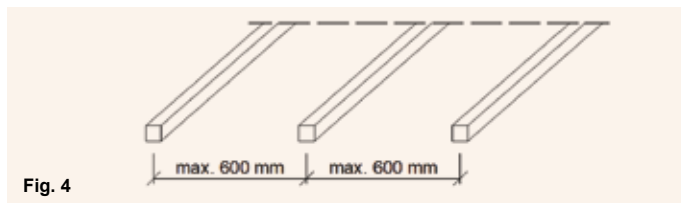

**VMG Lignum Board | Floor Regular** should always be perpendicular to the direction of the beams (Fig. 5). All short panel edges must be supported. **VMG Lignum Board | Floor Regular** must span at least two beam gaps, and connection must always be formed on the centre-line of a beam.

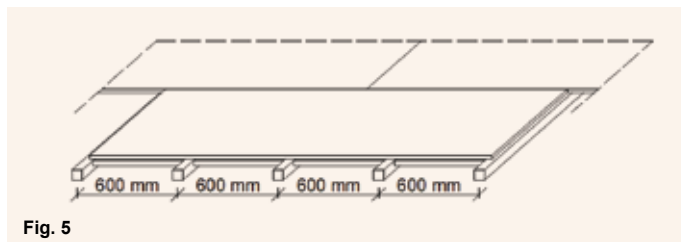

**VMG Lignum Board | Floor Regular** are nailed or screwed. In service class 1, galvanize steel or stainless steel and in service class 2 - hot galvanized steel or stainless steel fasteners must be used. The minimum length of fasteners must be at least 50 mm or twice the thickness of the panel, whichever is the longest. For nails, the minimum diameter is 0.16 times the thickness of the panel; and 0.2 times the thickness of the panel for screws. Minimal nails 3.0/50 mm, screws 3.6/50 mm.

The distance to the edge must be at least 12 mm, and to the corner - at least 25 mm (Fig. 6).

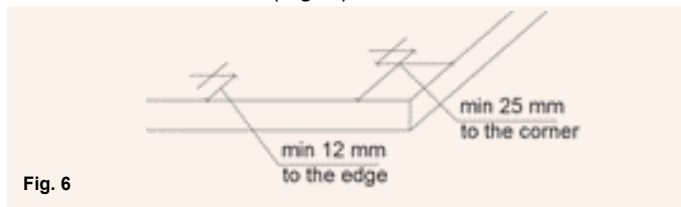

The spacing between fasteners is not more than 150 mm at the ends of the panel and not more than 300 mm on intermediate supports (Fig. 7).

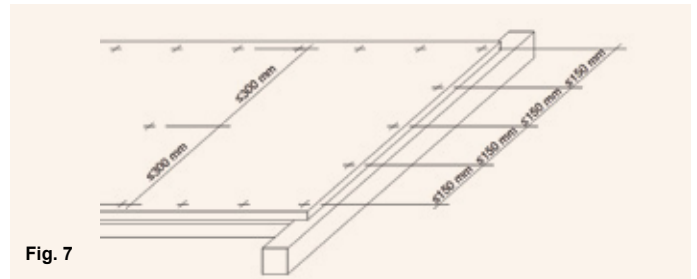

**VMG Lignum Board | Floor Regular** must be supported on 4 sides (Fig. 8). This support should be 18 mm at least (Fig. 9).

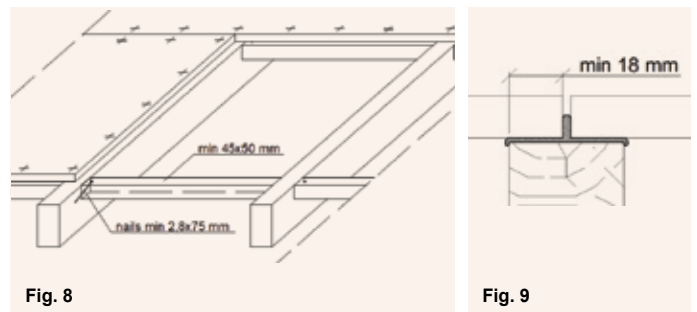

To prevent the floor from cracking, the **VMG Lignum Board | Floor Regular** must be glued (Fig. 10). Gluing the panels on the support beam contributes significantly to improving the overall resistance to vibrations of whole flooring. Recommendations for glues:

- in dry conditions, minimum PVAc, type D3.
- in wet conditions PVAc, type D4.

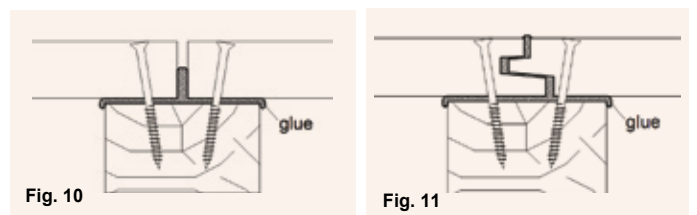

Against fixed structures, there must be a clearance of min 10 mm (Fig. 12). Large floor surfaces over 10 m long must be broken up into fields with expansion gaps between them.

**VMG Lignum Board | Floor Regular** are laid with an expansion joint of 4 mm for a panel width > 1 m (Fig. 13).

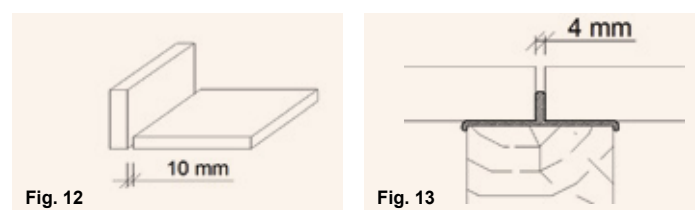

Before laying the top floor, it must be checked that the subfloor has good contact with the joists and does not creak. If it does, consider inserting more screws. **VMG Lignum Board | Floor Regular** damp content may not exceed 10% when the top floor is laid.

# VMG Lignum Board | Floor T&G2

## GENERAL

These guidelines are for the installation of **VMG Lignum Board | Floor T&G2**.

There are three types of **VMG Lignum Board | Floor**:

- has tongue and grooves on four sides **VMG Lignum Board | Floor T&G4**.
- has tongue and groove on two sides **VMG Lignum Board | Floor T&G2**.
- has straight edges **VMG Lignum Board | Floor Regular**.

Marking on plate should be always on bottom side of plate.

**VMG Lignum Board | Floor** contains 5-8 % moisture on delivery from factory. During assembling of plates, materials cannot get direct water (rain) and temperature should be +10°C at least.

The panels will move slightly in response to variations in air humidity.

## AREAS OF USE

**VMG Lignum Board | Floor** can be use as a floor (Service class 1&2).

## TRANSPORT, STORAGE, HANDLING

**VMG Lignum Board | Floor T&G2** must be protected from moisture during transport and storage. Panels must never be laid directly on the ground.

**VMG Lignum Board | Floor T&G2** should be stacked horizontally on wooden battens (100 x 80 mm). Wooden battens should be of the same dimensions and spaced no further than 950 mm apart. At the edges, **VMG Lignum Board | Floor T&G2** should not project from the last wooden battens by more 305 mm. Wooden battens should be vertically aligned to avoid damage (Fig. 1).

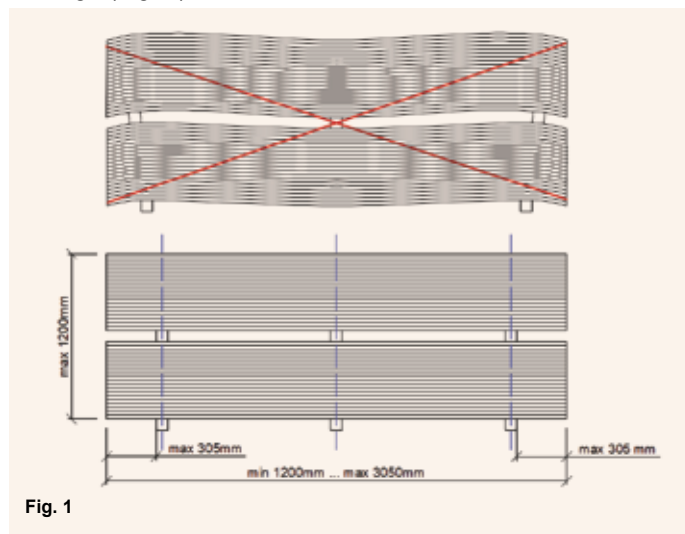

Fig. 1

## PLEASE HANDLE WITH CARE!

**VMG Lignum Board | Floor T&G2** should be carried by hand in a vertical position, not horizontal, in order to avoid breaking (Fig. 2).

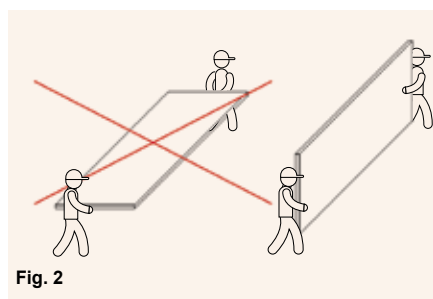

Fig. 2

Storage rooms must be protected from the direct sun and rain (Fig. 3).

Open shelters are not considered dry.

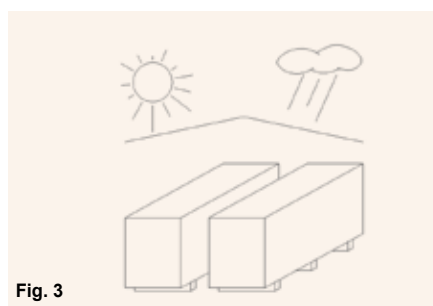

Fig. 3

## BEARING STRUCTURES

**VMG Lignum Board | Floor T&G2** can be placed on:

- wooden beams.
- metal beams.

# VMG Lignum Board | Floor T&G2

## INSTALLATION ON BEAMS

The moisture content of the wood beams cannot exceed 18 %. The bearing structure should be leveled. A vapour barrier can be placed between the bearing structure and **VMG Lignum Board | Floor T&G2**. The beams must be installed with exact centre-to-centre spacing, max c/c 600 mm (Fig. 4).

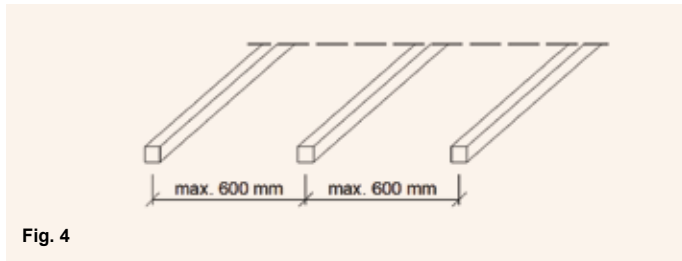

Fig. 4

**VMG Lignum Board | Floor T&G2** should always be parallel to main beams (Fig. 5). All short panel edges must be supported. **VMG Lignum Board | Floor T&G2** recommended to be span at least two beam gaps, and connection must always be formed on the centre-line of a beam.

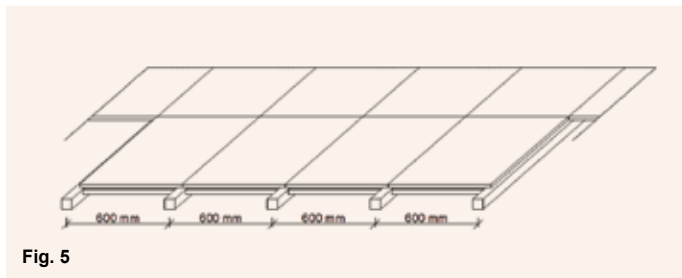

Fig. 5

**VMG Lignum Board | Floor T&G2** are nailed or screwed. In service class 1, galvanize steel or stainless steel and in service class 2 - hot galvanized steel or stainless steel fasteners must be used. The minimum length of fasteners must be at least 50 mm or twice the thickness of the panel, whichever is the longest. For nails, the minimum diameter is 0.16 times the thickness of the panel; and 0.2 times the thickness of the the panel for screws. Minimal nails 3.0/50 mm, screws 3.6/50 mm.

The distance to the edge must be at least 12 mm, and to the corner - at least 25 mm (Fig. 6).

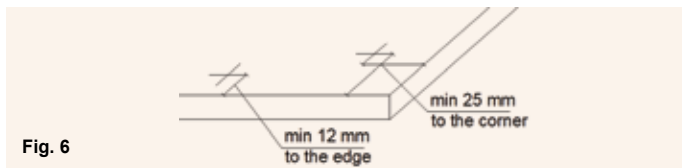

Fig. 6

The spacing between fasteners is not more than 150 mm at the ends of the panel and not more than 300 mm on intermediate supports (Fig. 7).

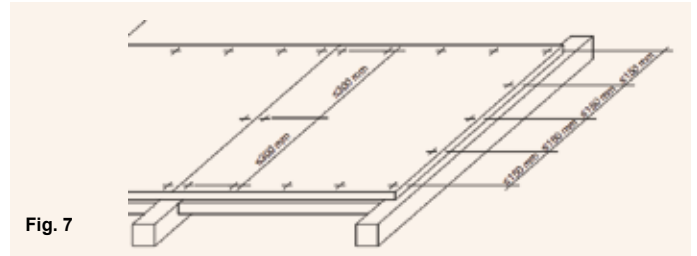

Fig. 7

**VMG Lignum Board | Floor T&G2** must be supported on 4 sides (Fig. 8). This support should be 18 mm at least (Fig. 9)

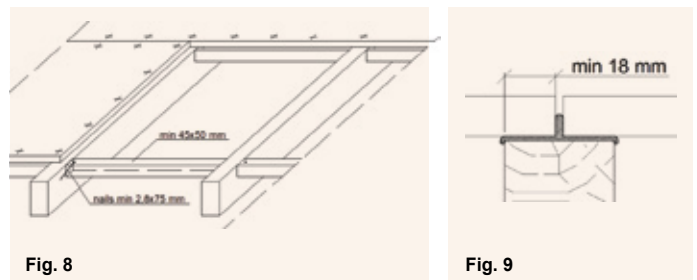

Fig. 8

Fig. 9

To prevent the floor from cracking, the **VMG Lignum Board | Floor T&G2** must be glued (Fig. 10 and Fig. 11). Gluing the panels on the support beam contributes significantly to improving the overall resistance to vibrations of whole flooring. Recommendations for glues:

- in dry conditions, minimum PVAc, type D3.
- in wet conditions PVAc, type D4.

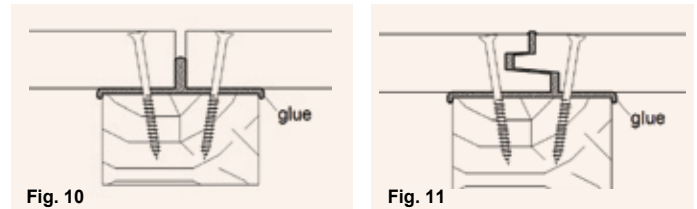

Fig. 10

Fig. 11

Against fixed structures, there must be a clearance of min 10 mm (Fig. 12). Large floor surfaces over 10 m long must be broken up into fields with expansion gaps between them.

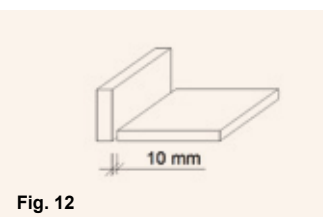

Fig. 12

**VMG Lignum Board | Floor T&G2** are laid with an expansion joint of 4 mm for a panel width > 1 m (Fig. 13).

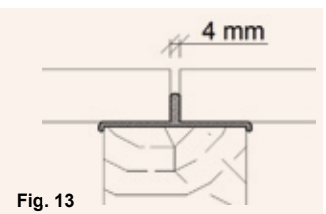

Fig. 13

Before laying the top floor, it must be checked that the subfloor has good contact with the joists and does not creak. If it does, consider inserting more screws. **VMG Lignum Board | Floor T&G2** damp content may not exceed 10% when the top floor is laid.

# VMG Lignum Board | Floor T&G4

## GENERAL

These guidelines are for the installation of **VMG Lignum Board | Floor**.

There are three types of **VMG Lignum Board | Floor**:

- has tongue and grooves on four sides **VMG Lignum Board | Floor T&G4**.
- has tongue and groove on two sides **VMG Lignum Board | Floor T&G2**.
- has straight edges **VMG Lignum Board | Floor Regular**.

Marking on plate should be always on bottom side of plate.

**VMG Lignum Board | Floor** contains 5-8 % moisture on delivery from factory. During assembling of plates, materials cannot get direct water (rain) and temperature should be +10°C at least.

The panels will move slightly in response to variations in air humidity.

## AREAS OF USE

**VMG Lignum Board | Floor** can be use as a floor (Service class 1&2).

## TRANSPORT, STORAGE, HANDLING

**VMG Lignum Board | Floor T&G4** must be protected from moisture during transport and storage. Panels must never be laid directly on the ground.

**VMG Lignum Board | Floor T&G4** should be stacked horizontally on wooden battens (100 x 80 mm). Wooden battens should be of the same dimensions and spaced no further than 950 mm apart. At the edges, **VMG Lignum Board | Floor T&G4** should not project from the last wooden battens by more 305 mm. Wooden battens should be vertically aligned to avoid damage (Fig. 1).

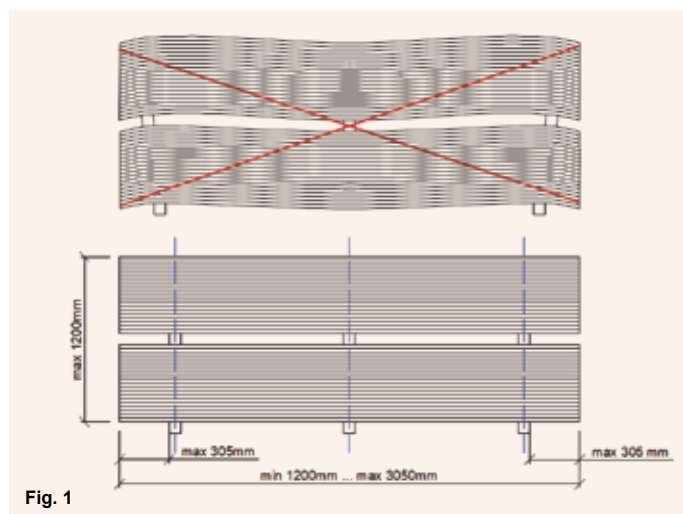

Fig. 1

The corners of the plates are protected at the factory.

## PLEASE HANDLE WITH CARE!

**VMG Lignum Board | Floor T&G4** should be carried by hand in a vertical position, not horizontal, in order to avoid breaking (Fig. 2).

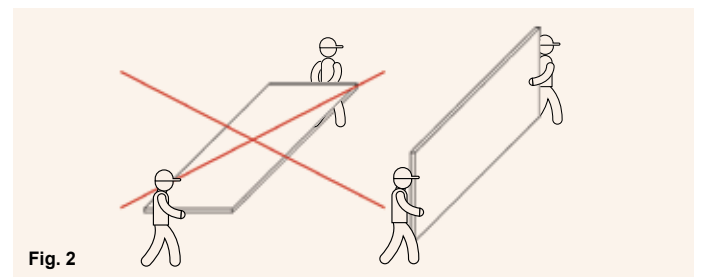

Fig. 2

Storage rooms must be protected from the direct sun and rain (Fig. 3). Open shelters are not considered dry.

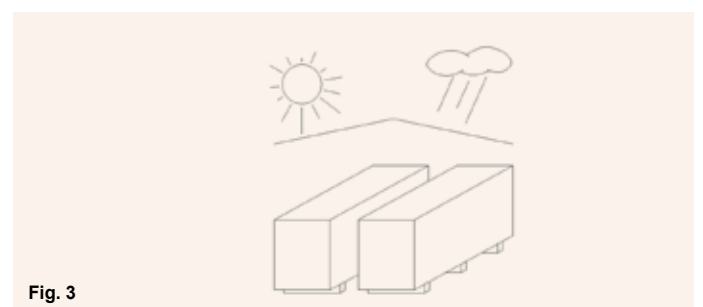

Fig. 3



# VMG Lignum Board | Floor T&G4

## BEARING STRUCTURES

VMG Lignum Board | Floor T&G4 can be placed on:

- wooden beams.
- metal beams.

## INSTALLATION ON BEAMS

The moisture content of the wood beams cannot exceed 18 %. The bearing structure should be leveled. A vapour barrier can be placed between the bearing structure and VMG Lignum Board | Floor T&G4. The beams must be installed with exact centre-to-centre spacing, max c/c 600 mm (Fig. 4).

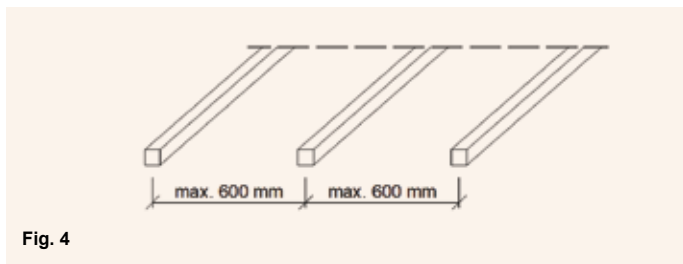

Fig. 4

VMG Lignum Board | Floor T&G4 should always be perpendicular to the direction of the beams (Fig. 5). All short panel edges must be supported. VMG Lignum Board | Floor T&G4 must span at least 600 mm gaps, and connection must always be formed on the centre-line of a beam. In this case minimum distance from beam to joint should be 160 mm. If the short joints end up between the same pair of beams, the distance between the short joints must be the minimum 360 mm.

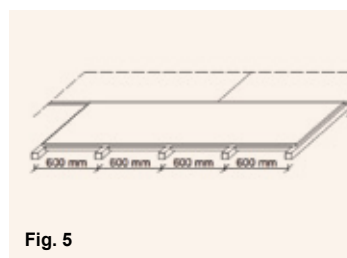

Fig. 5

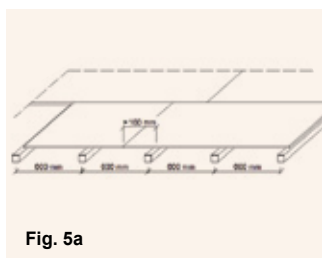

Fig. 5a

VMG Lignum Board | Floor T&G4 are nailed or screwed. In service class 1, galvanize steel or stainless steel and in service class 2 - hot galvanized steel or stainless steel fasteners must be used. The minimum length of fasteners must be at least 50 mm or twice the thickness of the panel, whichever is the longest. For nails, the minimum diameter is 0.16 times the thickness of the panel; and 0.2 times the thickness of the the panel for screws. Minimal nails 3.0/50 mm, screws 3.6/50 mm.

The distance to the edge must be at least 12 mm, and to the corner - at least 25 mm (Fig. 6).

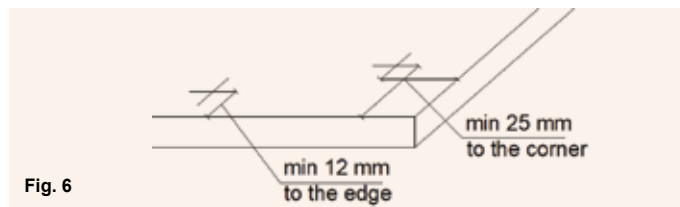

Fig. 6

The spacing between fasteners is not more than 150 mm at the ends of the panel and not more than 300 mm on intermediate supports (Fig. 7).

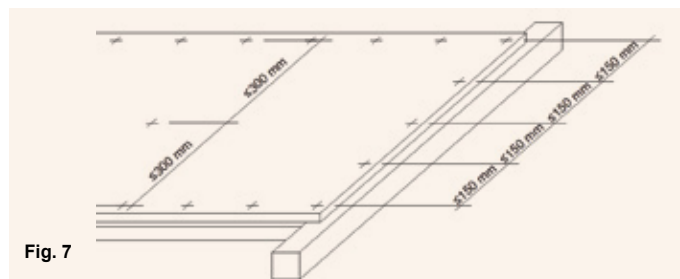

Fig. 7

To prevent the floor from cracking, the VMG Lignum Board | Floor T&G4 profiles must be fully glued (Fig. 8). The panels must be driven so tightly that adhesive emerges from the beam. Remove excess adhesive. Gluing the panels on the support beam contributes significantly to improving the overall resistance to vibrations of whole flooring. Recommendations for glues:

- in dry conditions, minimum PVAc, type D3.
- in wet conditions PVAc, type D4.

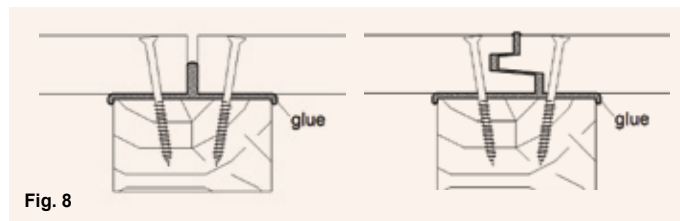

Fig. 8

Against fixed structures, there must be a clearance of min 10 mm (Fig. 9). Large floor surfaces over 10 m long must be broken up into fields with expansion gaps between them.

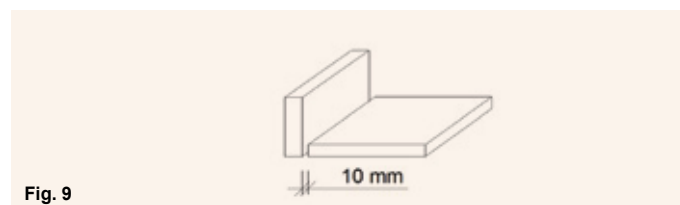

Fig. 9

Before laying the top floor, it must be checked that the subfloor has good contact with the joists and does not creak. If it does, consider inserting more screws. VMG Lignum Board | Floor T&G4 damp content may not exceed 10% when the top floor is laid.

# VMG Lignum Board | Wall Regular

## GENERAL

These guidelines are for the installation of **VMG Lignum Board | Wall Regular**

There are three types of **VMG Lignum Board | Wall**:

- has tongue and grooves on two sides **VMG Lignum Board | Wall T&G2**.
- has straight edges **VMG Lignum Board | Wall Regular**.

Marking on plate should be always on bottom side of plate.

**VMG Lignum Board | Wall** contains 5-8 % moisture on delivery from factory. During assembling of plates, materials cannot get direct water (rain) and temperature should be +10°C at least.

The panels will move slightly in response to variations in air humidity.

## AREAS OF USE

**VMG Lignum Board | Wall** can be use as a wall (Service class 1&2).

## TRANSPORT, STORAGE, HANDLING

**VMG Lignum Board | Wall** must be protected from moisture during transport and storage. Panels must never be laid directly on the ground.

**VMG Lignum Board | Wall** should be stacked horizontally on wooden battens (100 x 80 mm). Wooden battens should be of the same dimensions and spaced no further than 950 mm apart. At the edges, **VMG Lignum Board | Wall** should not project from the last wooden battens by more 305 mm. Wooden battens should be vertically aligned to avoid damage (Fig. 1).

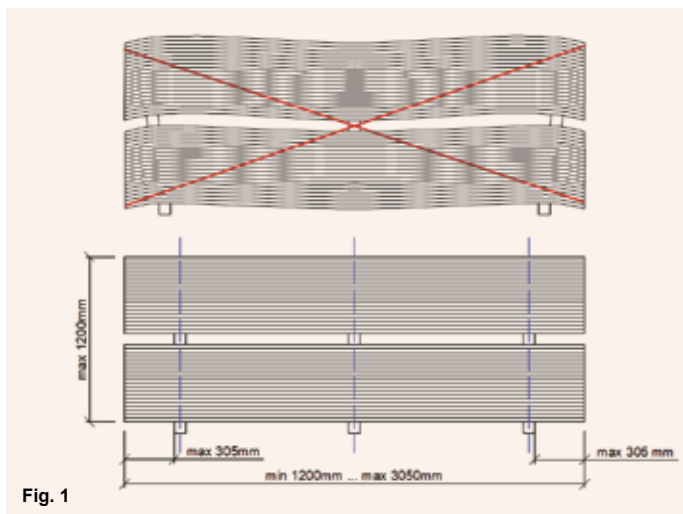

Fig. 1

## PLEASE HANDLE WITH CARE!

**VMG Lignum Board | Wall** should be carried by hand in a vertical position, not horizontal, in order to avoid breaking (Fig. 2).

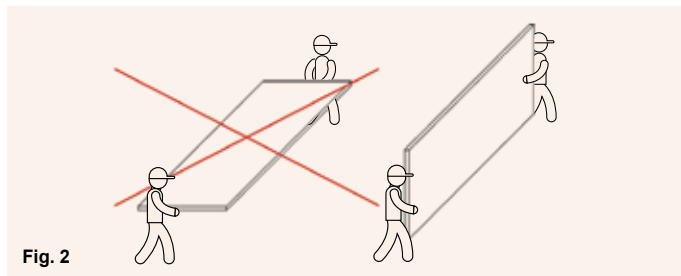

Fig. 2

Storage rooms must be protected from the direct sun and rain (Fig. 3). Open shelters are not considered dry.

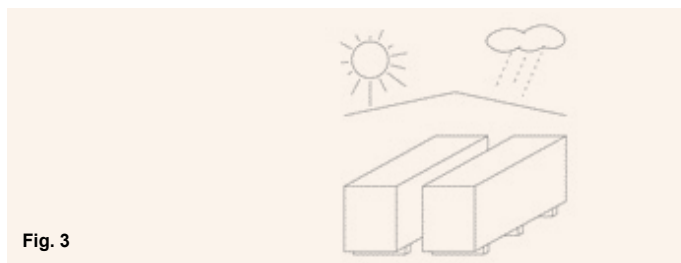

Fig. 3

## BEARING STRUCTURES

**VMG Lignum Board | Wall** can be placed on:

- wooden beams.
- metal beams.

# VMG Lignum Board | Wall Regular

## INSTALLATION ON BEAMS

The moisture content of the wood beams cannot exceed 18 %. The bearing structure should be leveled. A vapour barrier can be placed between the bearing structure and **VMG Lignum Board | Wall Regular**. The beams must be installed with exact centre-to-centre spacing, max. c/c 600 mm (Fig. 4).

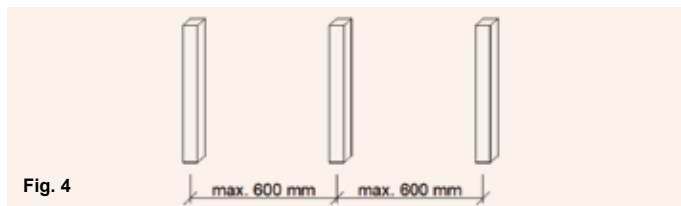

**VMG Lignum Board | Wall Regular** are nailed or screwed. In service class 1, galvanized steel or stainless steel and in service class 2 - hot galvanized steel or stainless steel fasteners must be used.

The minimum length of fasteners must be at least 50 mm or twice the thickness of the panel, whichever is the longest. For nails, the minimum diameter is 0.16 times the thickness of the panel; and 0.2 times the thickness of the panel for screws. Minimal nails 3.0/50 mm, screws 3.6/50 mm.

The distance to the edge must be at least 7 mm (Fig. 5)

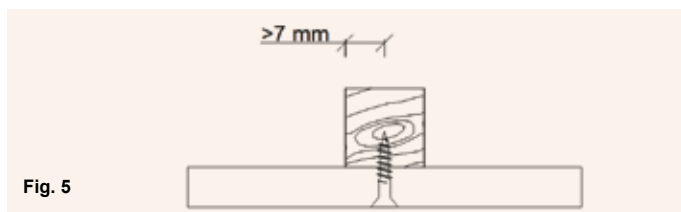

The spacing between fasteners is not more than 150 mm at the ends of the panel and not more than 300 mm on intermediate supports (Fig. 6).

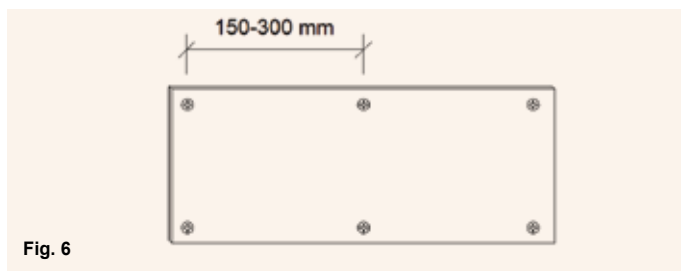

**VMG Lignum Board | Wall Regular** must be supported on 4 sides (Fig. 7). This support should be 18 mm at least (Fig. 8)

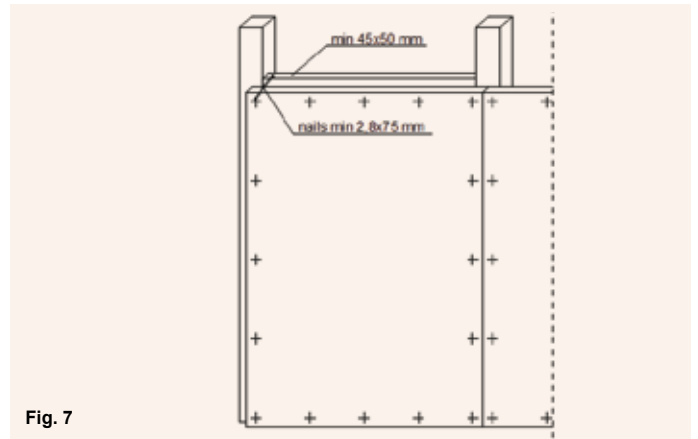

**VMG Lignum Board | Wall Regular** are laid with an expansion joint of 4 mm for a panel width > 1 m (Fig. 8).

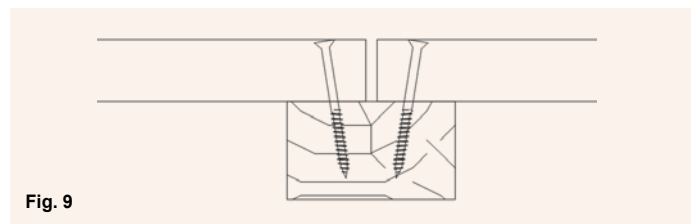
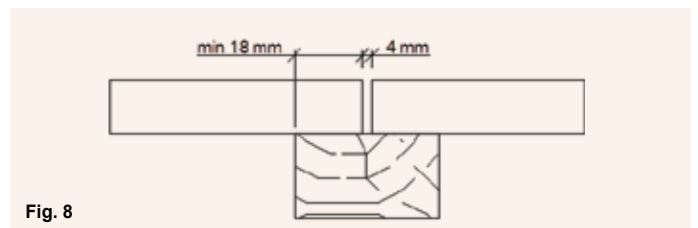

Against fixed structures, there must be a clearance of min. 10 mm (Fig. 10).

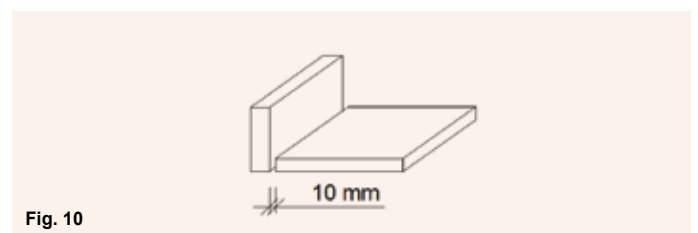

Before laying the top wall, it must be checked that the wall has good contact with the joists and does not creak. If it does, consider inserting more screws. **VMG Lignum Board | Wall Regular** damp content may not exceed 10% when the top wall is laid.

Link to the manufacturer's page: <https://vmg.eu/produkcija/4>

# VMG Lignum Board | Wall T&G2

## GENERAL

These guidelines are for the installation of **VMG Lignum Board | Wall T&G2**.

There are two types of **VMG Lignum Board | Wall**:

- has tongue and grooves on two sides **VMG Lignum Board | Wall T&G2**.
- has straight edges **VMG Lignum Board | Wall Regular**.

Marking on plate should be always on bottom side of plate.

**VMG Lignum Board | Wall** contains 5-8 % moisture on delivery from factory. During assembling of plates, materials cannot get direct water (rain) and temperature should be +10°C at least.

The panels will move slightly in response to variations in air humidity.

## AREAS OF USE

**VMG Lignum Board | Wall** can be use as a wall (Service class 1&2).

## TRANSPORT, STORAGE, HANDLING

**VMG Lignum Board | Wall T&G2** must be protected from moisture during transport and storage. Panels must never be laid directly on the ground.

**VMG Lignum Board | Wall T&G2** should be stacked horizontally on wooden battens (100 x 80 mm). Wooden battens should be of the same dimensions and spaced no further than 700 mm apart. At the edges, **VMG Lignum Board | Wall T&G2** should not project from the last wooden battens by more than 150 mm. Wooden battens should be vertically aligned to avoid damage (Fig. 1).

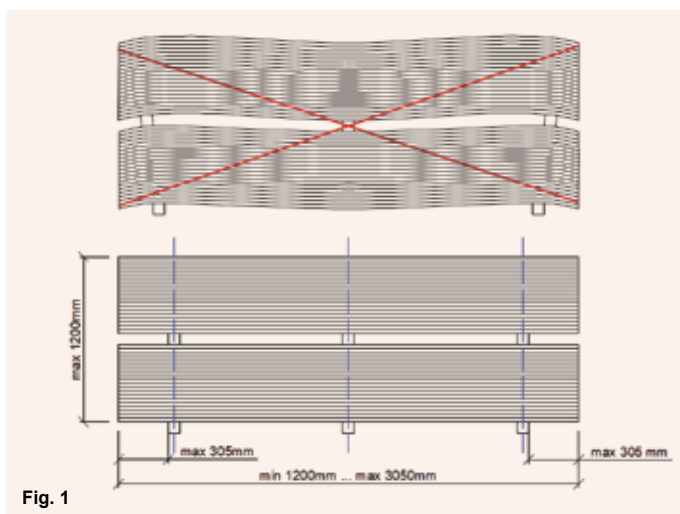

Fig. 1

## PLEASE HANDLE WITH CARE!

**VMG Lignum Board | Wall T&G2** should be carried by hand in a vertical position, not horizontal, in order to avoid breaking (Fig. 2).

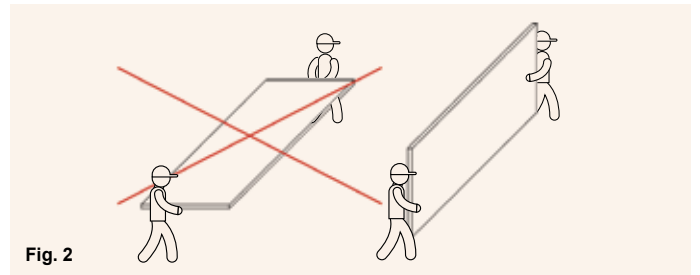

Fig. 2

Storage rooms must be protected from the direct sun and rain (Fig. 3). Open shelters are not considered dry.

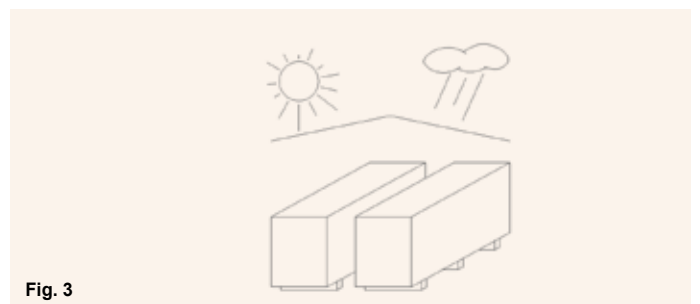

Fig. 3

# VMG Lignum Board | Wall T&G2

## BEARING STRUCTURES

VMG Lignum Board | Wall can be placed on:

- wooden beams.
- metal beams.

## INSTALLATION ON BEAMS

The moisture content of the wood beams cannot exceed 18 %. The bearing structure should be leveled. A vapour barrier can be placed between the bearing structure and VMG Lignum Board | Wall T&G2. The beams must be installed with exact centre-to-centre spacing, max. c/c 600 mm (Fig. 4).

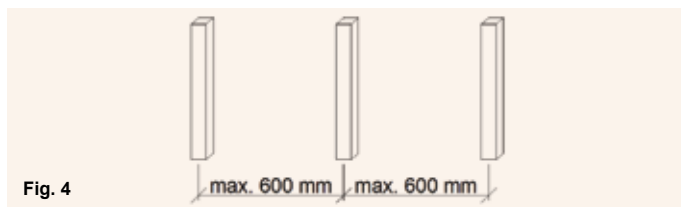

VMG Lignum Board | Wall T&G2 are nailed or screwed. In service class 1, galvanize steel or stainless steel and in service class 2 - hot galvanized steel or stainless steel fasteners must be used.

The minimum length of fasteners must be at least 25 mm or twice the thickness of the panel, whichever is the longest. For nails, the minimum diameter is 0.16 times the thickness of the panel; and 0.2 times the thickness of the panel for screws. Minimal nails 1.6/35 mm, screws 2.0/25 mm.

The spacing between fasteners is not more than 150 mm at the ends of the panel and not more than 300 mm on intermediate supports (Fig. 5).

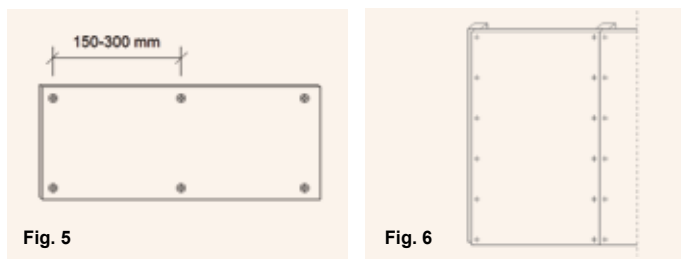

VMG Lignum Board | Wall T&G2 must be supported on 2 sides (Fig. 6). This support should be 18 mm at least (Fig. 8)

VMG Lignum Board | Wall T&G2 are laid with an expansion joint of 0,5-1 mm (Fig. 7).

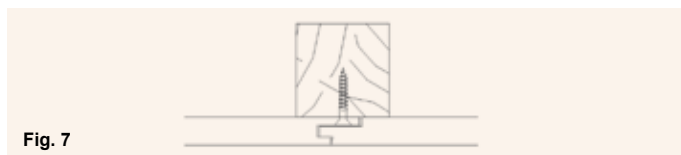

A corner fillet can be used on internal or external corners. Corner fillets must be installed before mounting boards. The installation instructions for internal corners are given in Fig. 8a, 8b, 8c and Fig. 9, for external corners Fig. 10. For internal corners chamber the back edge of the board. The board should be guided into base of fillet (Fig. 8a) and then pressed towards the wall (Fig. 8b). And then the board should be pulled back, engaging the tongue and groove (Fig. 8c).

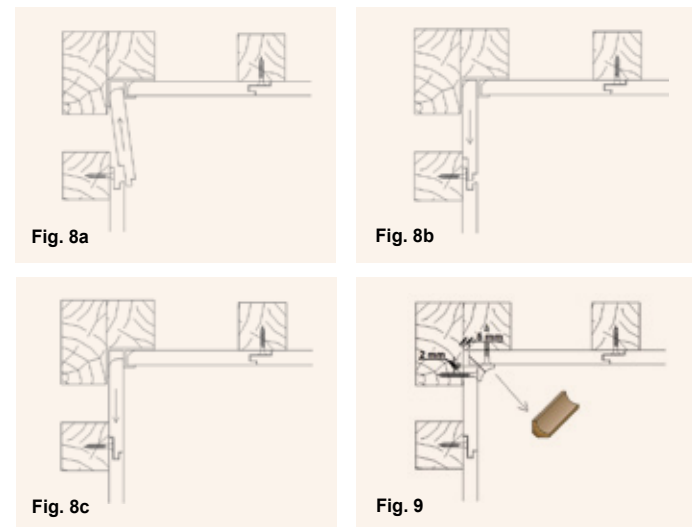

For external corners the first board should be cut 3mm in length, the final board – 10 mm. Edge of the board must be chamfer. The board marked with number 1 is installed first and then board marked with number 2.

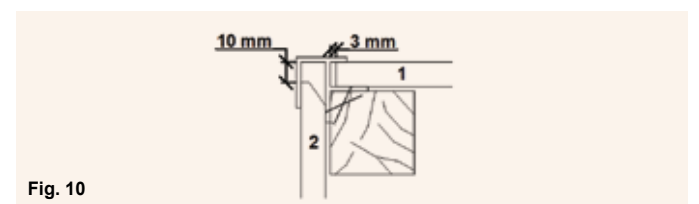

Against fixed structures, there must be a clearance of min. 10 mm (Fig. 11).

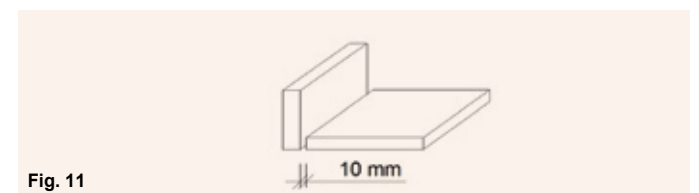

Before laying the top wall, it must be checked that the wall has good contact with the joists and does not creak. If it does, consider inserting more screws. VMG Lignum Board | Wall T&G2 damp content may not exceed 10% when the top wall is laid.